

FORM PTO-1390 (REV 11-2000)	U.S. DEPARTMENT OF COMMERCE PATENT AND TRADEMARK OFFICE	ATTORNEY'S DOCKET NUMBER 36-1445
TRANSMITTAL LETTER TO THE UNITED STATES DESIGNATED/ELECTED OFFICE (DO/EO/US) CONCERNING A FILING UNDER 35 U.S.C. 371		U.S. APPLICATION NO. (If known, see 37 C.F.R. 1.5) 09/830459 Unknown
INTERNATIONAL APPLICATION NO. PCT/GB99/03870	INTERNATIONAL FILING DATE 19 November 1999	PRIORITY DATE CLAIMED 27 November 1998

TITLE OF INVENTION
ANNOUNCED SESSION CONTROL

APPLICANT(S) FOR DO/EO/US
BELL et al

Applicant herewith submits to the United States Designated/Elected Office (DO/EO/US) the following items and other information:

1. This is a **FIRST** submission of items concerning a filing under 35 U.S.C. 371.
2. This is a **SECOND** or **SUBSEQUENT** submission of items concerning a filing under 35 U.S.C. 371.
3. This is an express request to begin national examination procedures (35 U.S.C. 371(f)). The submission must include items (5), (6), (9) and (21) indicated below.
4. The U.S. has been elected by the expiration of 19 months from the priority date (Article 31).
5. A copy of the International Application as filed (35 U.S.C. 371(c)(2)).
 - a. is attached hereto (required only if not communicated by the International Bureau).
 - b. has been communicated by the International Bureau.
 - c. is not required, as the application was filed in the United States Receiving Office (RO/US).
6. An English language translation of the International Application as filed (35 U.S.C. 371(c)(2)).
 - a. is attached hereto.
 - b. has been previously submitted under 35 U.S.C. 154(d)(4).
7. Amendments to the claims of the International Application under PCT Article 19 (35 U.S.C. 371(c)(3))
 - a. are attached hereto (required only if not communicated by the International Bureau).
 - b. have been communicated by the International Bureau.
 - c. have not been made; however, the time limit for making such amendments has **NOT** expired.
 - d. have not been made and will not be made.
8. An English language translation of the amendments to the claims under PCT Article 19 (35 U.S.C. 371(c)(3)).
9. An oath or declaration of the inventor(s) (35 U.S.C. 371(c)(4)).
10. A English language translation of the annexes of the International Preliminary Examination Report under PCT Article 36 (35 U.S.C. 371(c)(5)).

Items 11 To 20 below concern document(s) or information included:

11. An Information Disclosure Statement under 37 C.F.R. 1.97 and 1.98.
12. An assignment document for recording. A separate cover sheet in compliance with 37 C.F.R. 3.28 and 3.31 is included.
13. A FIRST preliminary amendment.
14. A SECOND or SUBSEQUENT preliminary amendment.
15. A substitute specification.
16. A change of power of attorney and/or address letter.
17. A computer-readable form of the sequence listing in accordance with PCT Rule 13ter.2 and 35 U.S.C. 1.821-1.825.
18. A second copy of the published international application under 35 U.S.C. 154(d)(4).
19. A second copy of the English language translation of the international application under 35 U.S.C. 154(d)(4).
20. Other items or information.

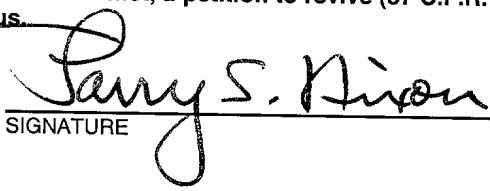
U.S. APPLICATION NO (If known, see 37 C.F.R. 1.5)		INTERNATIONAL APPLICATION NO		ATTORNEY'S DOCKET NUMBER	
Unknown 09, 830459		PCT/GB99/03870		36-1445	
21. <input checked="" type="checkbox"/> The following fees are submitted:				CALCULATIONS PTO USE ONLY	
BASIC NATIONAL FEE (37 C.F.R. 1.492(a)(1)-(5):					
-- Neither international preliminary examination fee (37 C.F.R. 1.482) nor international search fee (37 C.F.R. 1.445(a)(2)) paid to USPTO and International Search Report not prepared by the EPO or JPO				\$1000.00	
-- International preliminary examination fee (37 C.F.R. 1.482) not paid to USPTO but International Search Report prepared by the EPO or JPO.....				\$860.00	
-- International preliminary examination fee (37 C.F.R. 1.482) not paid to USPTO but international search fee (37 C.F.R. 1.445(a)(2)) paid to USPTO.....				\$710.00	
-- International preliminary examination fee (37 C.F.R. 1.482) paid to USPTO but all claims did not satisfy provisions of PCT Article 33(1)-(4).....				\$690.00	
-- International preliminary examination fee (37 C.F.R. 1.482) paid to USPTO and all claims satisfied provisions of PCT Article 33(1)-(4).....				\$100.00	
ENTER APPROPRIATE BASIC FEE AMOUNT =				\$	860.00
Surcharge of \$130.00 for furnishing the oath or declaration later than <input type="checkbox"/> 20 <input type="checkbox"/> 30 months from the earliest claimed priority date (37 C.F.R. 1.492(e)).				\$	0.00
CLAIMS	NUMBER FILED	NUMBER EXTRA	RATE		
Total Claims	31	-20 =	11	X	\$18.00
Independent Claims	2	-3 =	0	X	\$80.00
MULTIPLE DEPENDENT CLAIMS(S) (if applicable)			\$270.00	\$	0.00
TOTAL OF ABOVE CALCULATIONS =				\$	1058.00
<input type="checkbox"/> Applicant claims small entity status. See 37 CFR 1.27. The fees indicated above are reduced by 1/2.					0.00
SUBTOTAL =				\$	1058.00
Processing fee of \$130.00, for furnishing the English Translation later than <input type="checkbox"/> 20 <input type="checkbox"/> 30 months from the earliest claimed priority date (37 C.F.R. 1.492(f)).					0.00
TOTAL NATIONAL FEE =				\$	1058.00
Fee for recording the enclosed assignment (37 C.F.R. 1.21(h)). The assignment must be accompanied by an appropriate cover sheet (37 C.F.R. 3.28, 3.31). \$40.00 per property				+	\$ 40.00
Fee for Petition to Revive Unintentionally Abandoned Application (\$1240.00 - Small Entity = \$620.00)				\$	0.00
TOTAL FEES ENCLOSED =				\$	1098.00
				Amount to be:	
				refunded	\$
				Charged	\$
<p>a. <input checked="" type="checkbox"/> A check in the amount of \$1098.00 to cover the above fees is enclosed.</p> <p>b. <input type="checkbox"/> Please charge my Deposit Account No. 14-1140 in the amount of \$_____ to cover the above fees. A duplicate copy of this form is enclosed.</p> <p>c. <input checked="" type="checkbox"/> The Commissioner is hereby authorized to charge any additional fees which may be required, or credit any overpayment to Deposit Account No. 14-1140. A duplicate copy of this form is enclosed.</p> <p>d. <input checked="" type="checkbox"/> The entire content of the foreign application(s), referred to in this application is/are hereby incorporated by reference in this application.</p>					
<p>NOTE: Where an appropriate time limit under 37 C.F.R. 1.494 or 1.495 has not been met, a petition to revive (37 C.F.R. 1.137(a) or (b)) must be filed and granted to restore the application to pending status.</p>					
<p>SEND ALL CORRESPONDENCE TO:</p> <p>NIXON & VANDERHYE P.C. 1100 North Glebe Road, 8th Floor Arlington, Virginia 22201-4714 Telephone: (703) 816-4000</p>					
				 SIGNATURE	
				Larry S. Nixon NAME	
				25,640 REGISTRATION NUMBER	
				April 27, 2001 Date	

09/830459

IN THE UNITED STATES PATENT AND TRADEMARK OFFICE

In re Patent Application of

JCG8 Rec'd PCT/PTO 27 APR 2001

BELL et al

Atty. Ref.: **36-1445**

Serial No. **Unknown**

Group:

National Phase of: **PCT/GB99/03870**

International Filing Date: **19 November 1999**

Filed: **April 27, 2001**

Examiner:

For: **ANNOUNCED SESSION CONTROL**

* * * * *

April 27, 2001

Assistant Commissioner for Patents
Washington, DC 20231

Sir:

PRELIMINARY AMENDMENT

Prior to calculation of the filing fee and in order to place the above identified application in better condition for examination, please amend the claims as follows:

IN THE CLAIMS

Please substitute the following amended claims for corresponding claims previously presented. A copy of the amended claims showing current revisions is attached.

4. (Amended) A method according to claim 1, in which the media applications select one or more of the media streams identified in the session description which are required and pass respective connection requests to the session control.

5. (Amended) A method according to claim 1, further comprising the step of passing at least a portion of the session description to the or each media application.

FOR THE "SESSION CONTROL"

7. (Amended) A method according to claim 5, in which the media applications modify the session description for changing the subsequent management of connections by the session control system.

8. (Amended) A method according to claim 4, in which the session control passes the connection requests to a terminal communications manager which determines whether the connection requests are viable and subsequently initiates the connections.

10. (Amended) A method according to claim 8, in which the communications manager determines resources required for each connection request and whether the requests can be met given available resources.

15. (Amended) A method according to claim 1, further comprising the step of obtaining a missing part of the session description by following a link or links in the session description before parsing the session description.

18. (Amended) A system according to claim 16, in which the session control is arranged to pass at least a portion of the session description to the or each media application.

20. (Amended) A system according to claim 18, in which the media applications are arranged to modify the session-description for changing the subsequent management of connections by the session control.

21. (Amended) A system according to claim 16, further comprising a communications manager for initiating the connections.

23. (Amended) A system according to claim 21, in which the session control system is adapted to prioritise the connection requests for the one or more media streams from the media applications according to a quality of service policy to create a set of connection requests which are passed to the communications manager.

24. (Amended) A system according to claim 21, in which the communications manager is arranged to determine resources required for each connection request in sequence and whether the connection requests can be met given available resources.

29. (Amended) A system according to claim 16, further comprising an announcement interface which is arranged to detect missing modules in a received session description and subsequently obtain them using location identifying links provided in the session description.

30. (Amended) A computer readable storage medium containing executable instructions for performing the method of claim 1.

BELL et al
Serial No. **Unknown**

31. (Amended) A terminal comprising at least one memory containing executable instructions for performing the method of claim 1.

REMARKS

Attached hereto is a marked-up version of the changes made to the claims by the current amendment. The attached page is captioned "**Version with markings to show changes made.**"

The above amendments are made to place the claims in a more traditional format.

Respectfully submitted,

NIXON & VANDERHYE P.C.

By:

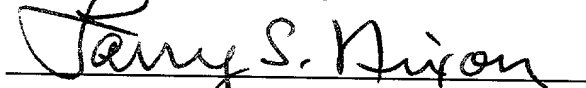

Larry S. Nixon

Reg. No. 25,640

LSN:Imy

1100 North Glebe Road, 8th Floor
Arlington, VA 22201-4714
Telephone: (703) 816-4000
Facsimile: (703) 816-4100

FOIA b 7 - EXEMPT

VERSION WITH MARKINGS TO SHOW CHANGES MADE

4. (Amended) A method according to [any preceding claim] claim 1, in which the media applications select one or more of the media streams identified in the session description which are required and pass respective connection requests to the session control.

5. (Amended) A method according to [any preceding claim] claim 1, further comprising the step of passing at least a portion of the session description to the or each media application.

7. (Amended) A method according to claim 5 [or 6], in which the media applications modify the session description for changing the subsequent management of connections by the session control system.

8. (Amended) A method according to [any of claims 4 to 7] claim 4, in which the session control passes the connection requests to a terminal communications manager which determines whether the connection requests are viable and subsequently initiates the connections.

10. (Amended) A method according to claim 8 [or 9], in which the communications manager determines resources required for each connection request and whether the requests can be met given available resources.

FOR THE "SHOW" B&B

15. (Amended) A method according to [any preceding claim] claim 1, further comprising the step of obtaining a missing part of the session description by following a link or links in the session description before parsing the session description.

18. (Amended) A system according to claim 16 [or 17], in which the session control is arranged to pass at least a portion of the session description to the or each media application.

20. (Amended) A system according to claim 18 [or 19], in which the media applications are arranged to modify the session-description for changing the subsequent management of connections by the session control.

21. (Amended) A system according to [any of claims 16 to 20] claim 16, further comprising a communications manager for initiating the connections.

23. (Amended) A system according to claim 21 [or 22], in which the session control system is adapted to prioritise the connection requests for the one or more media streams from the media applications according to a quality of service policy to create a set of connection requests which are passed to the communications manager.

24. (Amended) A system according to [any of claims 21 to 23] claim 21, in which the communications manager is arranged to determine resources required for

each connection request in sequence and whether the connection requests can be met given available resources.

29. (Amended) A system according to [any of claims 16 to 28] claim 16, further comprising an announcement interface which is arranged to detect missing modules in a received session description and subsequently obtain them using location identifying links provided in the session description.

30. (Amended) A computer readable storage medium containing executable instructions for performing the method of [any of claims 1 to 15] claim 1.

31. (Amended) A terminal comprising at least one memory containing executable instructions for performing the method of [any of claims 1 to 15] claim 1.

FOR "SEARCH" USE ONLY

7/PRTS

09/830459

JG08 Rec'd PCT/PTO

27 APR 2001

ANNOUNCED SESSION CONTROL

The present invention relates to the announcement of media stream connections for a media session over a communications network.

5 Multicast transmissions are becoming increasingly common on the Internet. In contrast to standard Internet Protocol (IP) point to point transmissions (unicast), IP multicast allows the simultaneous transmission of information to a group of recipients from a single source. Routing support for IP multicast transmissions is provided by the MBone (IP Multicast Backbone) which is a virtual network layered on top of the
10 Internet.

IP multicast allows real-time communications over wide area IP networks and typical transmissions include video and audio conferencing, live multimedia training, university lectures and transmission of live television programmes.

A multicast transmission usually consists of a multimedia session made up of
15 several individual media streams typically carrying video, audio, whiteboard or raw data. Some sessions are persistent, but the majority exist for a specific period of time, although need not be continuous. Multicast based transmissions on the MBone differ from unicast IP transmissions in that any user receiving the transmission can join the session (unless the transmission is encrypted) and to receive a transmission, a user
20 need only know the appropriate transmission address and timing information.

Prior to a multicast transmission an appropriate announcement containing a session description is made, usually at an IP group multi-cast address. Standard session descriptions are generated using a Session Description Protocol (SDP), as defined in the Internet Engineering Task Force's draft RFC 2327. SDP is a simple ASCII text based
25 protocol that is used to describe real time multimedia sessions and their related scheduling information. SDP messages are wrapped in a carrier protocol, known as a Session Announcement Protocol (SAP), which, in addition to containing the necessary

09830459 "042701

IP addressing and routing information for transmission across the Internet or Mbone, allows the SDP message to be encrypted, signed or compressed. An announcement can then be sent at regular intervals to the announcement group address. As an alternative to SAP, a session may be announced by placing an SDP message on a World Wide Web site (WWW) or by sending it to individuals by email or as a unicast transmission inviting them to participate.

An SDP message conveys information about each media stream in the multicast multimedia session to allow the recipients to participate in the session. A typical SDP message will include the session name and purpose, the time(s) and date(s) the session will be active, the component media streams of the session and information required to participate in each media stream (IP multicast address, port, media format). The SDP message may also include details of the session's bandwidth requirements, an encryption key necessary to participate in a secure multicast transmission using public key encryption, contact information for the organiser of the multicast session, and a Unique Resource Indicator (URI) pointing to a WWW or an Intranet web site where further information on the session may be found, for example, background information relating to the conference.

The level of participation a user may make in a session or stream depends on its purpose. In a multicast television session, typically users would only be able to receive the session streams whilst in a multicast conference session the communication would be bi-directional with a central server (such as group address 120) receiving each participants transmissions and relaying them to the other participants. The level of participation expected of a user in a session or stream may be explicitly stated in the session description or it may be inherent from the session description, for example when a receive-only application is associated with a media stream type in the session description.

A common front end interface used by multicast end users is known as Session Directory Rendezvous (SDR). This interface takes the received announcements, decodes the SDP message and displays the names of those sessions that are still current in a list. The end user may then select one of the listed announcements to view further technical and user-oriented details of the announced session. From the displayed information, the end user can then select to join individual streams of the session or to join the entire session. Once the streams to be joined are selected, SDR starts the necessary multicast-enabled multimedia application on the end user's computer, such as Vic and Vat, and passes the relevant stream information (a transport port address) from the announcement onto the application allowing the application to establish the link to the associated IP multicast address and participate in the stream at transmission time. Having initiated the applications and passed the relevant transport port address SDR plays no further part in the session.

Recent increased usage and demand for (multi)media sessions has highlighted a number of limitations in SDP. SDP limits session descriptions to defining a session having a single set of timings that apply to all of the streams within it. A session in which a stream starts mid-way through the transmission cannot easily be described using SDP. The structure of a session description written in SDP must be a simple linear list of streams which may not reflect the intuitive structure of a complex session. SDP supports a limited and predefined set of applications which can receive the streams and a limited and predefined set of transport mechanisms (e.g. Simple layering, RTP and UDP). As guaranteed Quality of Service (QoS) is becoming more and more desirable to the consumer and the supplier, the need to define QoS policies for the entire session and individual streams in terms of required system resources, bandwidth requirements and supported applications also needs to be met. There may also be requirements on the prioritisation of streams and subsessions or more complicated rules about receiving

streams. A further requirement on the part of the supplier will be the need for charging facilities permitting the charging of an end user for a multicast transmission to which they subscribe according to the QoS and types of streams received etc. There is little scope to include information about QoS policies or charging within the conventional structure of an SDP session description, or any metadata about the session.

A problem faced by providers of current (multi)media sessions and the developers of the associated (multi)media applications is the spread of skills required to implement an application that can initiate and manage a real-time data connection over a communications network and perform the (multi)media functions the end user would expect. For example, developers of multimedia applications require teams with skills in audio and video coding, network transport protocols, real time programming, user interface design and integration techniques. Furthermore, until now the only way a QoS policy could be implemented was to process a session description to determine which streams of a session could or should be run and then to initialise the applications so they connect to the respective streams. This required the communications manager not only to know about the session requirements and available system resources but also the capabilities of each application.

According to a first aspect of the invention there is provided a method of managing media stream connections for a media session, said method comprising the steps:-

- receiving a session description of a media session;
- parsing the session description to determine appropriate media application programs for processing the or each media stream of the session description;
- selecting one or more media streams identified in the session description; and,
- connecting the or each selected media stream to one or more respective media application program or programs utilising a session control configured for managing

media stream connections for the or each media application program.

Preferably, the selection of the or each media stream is carried out by the session control according to predetermined criteria.

5 In preferred embodiments, the predetermined criteria are specific to the preferences of at least one of the group consisting of an end-user, the terminal and the or each media application program.

Conveniently, the media applications select one or more of the media streams identified in the session description which are required and pass respective connection requests to the session control.

10 Preferably, the method further comprises the step of passing at least a portion of the session description to the or each media application.

In preferred embodiments the media applications generate or modify a quality of service policy for the connection requests for use by the session control.

15 Conveniently, the media applications modify the session description for changing the subsequent management of connections by the session control system.

Preferably, the session control passes the connection requests to a terminal communications manager which determines whether the connection requests are viable and subsequently initiates the connections.

20 In preferred embodiments, the session control prioritises the connection requests from the media applications according to a quality of service policy to create a set of connection requests which are passed to the communications manager.

Conveniently, the communications manager determines resources required for each connection request and whether the requests can be met given available resources.

25 Preferably, if the connection requests can be met the connections are initiated. If a connection request cannot be met and the connection request is for an optional media

stream of the media session then the communications manager proceeds by declaring the connection request unviable and moves to the next connection request. If a connection request cannot be met and the connection request is for a mandatory media stream of the media session then the communications manager proceeds by attempting to free resources to meet the connection request, and if the communications manager is unable to free sufficient resources to meet the connection request, the connection request is declared unviable and the communications manager refuses to join the media session.

In preferred embodiments the method further comprises the step of obtaining a missing part of the session description by following a link or links in the session description before parsing the session description.

According to a second aspect of the invention there is provided a system for managing media stream connections derived from a session description for a media session, the system comprising a session control for parsing the session description to determine appropriate media application programs for processing the or each media stream of the session description; the session control being configured to manage media stream connections for the media applications programs.

In a preferred example of the present invention media modules of a modular session description are checked by the respective multimedia client application prior to QoS management, thereby reducing the workload of the communications manager, that is to say the respective client applications determine whether the media modules can be supported. The applications may also add to or modify the session description to include their own QoS policies or to change the way in which the session and/or its initiation will be managed. Furthermore, applications need only request streams from the session control system associated with the client since the session control now handles centrally the creation and management of streams in real time. In this way the

present invention simplifies application development and service provision.

A further problem is that applications should be able to adapt to available network and host resources. This is particularly important for multi-party applications operating in heterogeneous environments where each party may have different resources available to them. Furthermore the nature of the heterogeneity may vary over the lifetime of the session, for example as network congestion varies or as the terminal resources are shared with other applications or other users. The present invention is able to use a QoS policy incorporated within the session description to prioritise the allocation of resources and to determine whether participation in the session is viable.

A further problem is that the application developer and service provider typically need to address security and charging requirements. The present invention allows security and charging policies to be incorporated within the session description for use within the session control system to invoke appropriate charging and security procedures. Instead of having to develop security and charging functions the application developer and service provider need only specify appropriate policies.

In the present invention application development is simplified by using the session description to drive the dynamic management of communication channels and to adapt to available resources. It also reduces the problem of handling charging and security requirements to a matter of specifying charging and security policies within the session description.

The present invention is particularly useful when used in conjunction with the modular session description described in this patent application and which is also the subject of our co-pending UK patent application 9826158.9

An example of the present invention will now be described in detail with reference to the accompanying drawings, in which:

Figure 1 is a schematic diagram illustrating a multicast transmission across the

MBone;

Figure 2 is a schematic diagram illustrating the distribution of an SDP announcement;

5 Figure 3 is a block diagram of a modular session description of a simple session generated in accordance with the present invention;

Figure 4 is a block diagram of a modular session description of a complex session generated in accordance with the present invention;

Figure 5 is a schematic diagram of a system for managing media stream connections;

10 Figure 6 is a flow chart illustrating the steps involved in managing a media session according to the system of Figure 5; and,

Figure 7 is a flow chart further illustrating a parsing step of Figure 6.

15 An example of an IP multicast transmission system is described with reference to Figure 1. Prior to a multicast transmission, an appropriate announcement containing a session description is made, thereby allowing end users 110a-110e to elect to receive the transmission. Each end user electing to receive the transmission is linked to a group IP Multicast address 120 associated with the transmission. At the transmission time of the multicast session, the session streams are transmitted from a source 130, or a plurality of sources, to the group address. At the group address, the transmission is
20 disseminated along the links 140 to those end users who have elected to receive it (in this example end users 110a-110c).

25 An example of an announcement and election system is described with reference to Figure 2. Most public multicast sessions are announced at a single group IP multicast address 200 dedicated to the transmission of announcements to multicast end users. End users 210a-210e electing to receive the announcements are linked to the announcement group address and, in the same way as an actual session

FOR THE "SHE" 6340360

transmission, each announcement arriving at the announcement group address is disseminated to the end users. A front end interface 220 on each end user's computer displays information obtained from the associated session description for each announcement. The minimum information a session description may contain is a time and date that the session will be active and the group IP multicast address(es) from which the end user may elect to receive one or more media streams and to which they could send their own streams for the session. Using the front end interface, an end user can select the announced session(s), or their component stream(s) they wish to participate in.

Figure 3 is a block diagram of a session description 300 for a simple multicast television session. The session description 300 comprises a base module 310 linked to a media module 320.

The base module 310 contains user oriented data relating to the session including the title and timing information. The base module 310 may also include a description or abstract, contact information about the organiser and a WWW or an intranet URI pointing to a web site containing further information. Ideally, the base module 310 should contain enough information for the user to decide if they are interested in participating in the session.

The media module 320 contains announcement data relating to a video stream of the session. The media module 320 contains the technical information (data) necessary for the user to receive the associated media stream. In particular, connection, timing and media format details are provided.

A first example of a session description 300 generated for transmission to end users is shown below:

```

type=(base)
id=(310)
info=(title="live multicast television session")
source=(name="A.Sender" email=asender@tx.com)
media=(video=(client=odbits0.16))
time=(length=50m repeat=continuous)
category=("Entertainment")
options=(none)
modules=(m=320)
)

(
type=(media)
id=(320 310)
media=(video=(client=odbits0.16))
connection=(229.1.1.2/7000)
time=(length=50m)
)

```

Session description example 1

The base module 310 has a unique identifier (id field) used in the generation of links between two modules during the processing of the session description. The modules field of the base module 310 lists the type and unique identifier of the media module 320 linked to the base module 310. The second identifier in the id field of the media module 320 is the unique identifier belonging to the base module 310 linking the media module back to the base module 310. By extension, these two-way links permit a module tree to be traversed from a base module downwards or from a media module upwards. The use of this feature is described later with reference to session description example 4.

The connection field of the media module 320 contains the IP multicast address and port number from which the media stream can be received.

Figure 4 is a block diagram of a session description 400 for a complex multicast session of a multimedia conference with two tracks, or sub-sessions, and a panel discussion. Each track provides multiparty video and audio conferencing and a shared whiteboard for leaving notes and messages. The panel discussion is encrypted and the

whole conference is subject to a subscription fee payable in advance by each participant.

The session description 400 contains a top level base module 410 linked to further base modules 420, 430, 440 and an options module 411. The top level base module 410 contains data relating to the overall session including its name, purpose and timing information. The options module 411 contains details of the payment mechanism for subscription fees.

Each further base module 420, 430, 440 relates to a subsession of the conference. Base module 420 relates to the first track of the conference. The base module 420 is linked to media modules 421-423, each containing connection, timing and media format data for respective video, audio and whiteboard streams.

The base module 420 is also linked to options module 424 which contains data relating to a QoS policy for the first track defining which media modules are optional and which are mandatory for a participant of the first track. The mandatory list contains identifiers of those media modules which are needed for the session or subsession to operate correctly whilst the optional list contains identifiers of the media modules that are not necessary for the session or subsession to operate correctly if system resources are scarce.

The base module 430 relates to the second track of the conference. It is linked to media modules 431-433, each containing connection, timing and media format details for respective video, audio and whiteboard streams. The base module 430 is also linked to options module 434 which contains data relating to a QoS policy for the second track defining which media modules are optional and which are mandatory for a participant of the second track. Base module 440 relates to the panel discussion. It is linked to media modules 441 and 442, each containing connection, timing and media format details for respective video and audio streams of the panel discussion. The base

module 440 is also linked to options module 443 which contains encryption details (ie. how and where to get the necessary cryptographic keys) necessary for a participant to decode the panel discussion media streams 441, 442 according to a known encryption mechanism such as DES or public key encryption.

5 The video media stream defined in media module 441 is layered. Layering of media streams allows users with different system resources to receive as much of the stream as their system resources allows. Every user must receive the bottom layer of the stream containing the minimum stream data. However, if a user has sufficient free system resources they can receive the next layer up containing enhancements to the
10 previous layer. Successive layers can be received enhancing the received media stream until the maximum number of layers is received or all free system resources capacity is used. The media module 441 is linked to an options module 444 which contains data on the layering necessary for the end user to be able to receive the layered stream correctly.

15 The portion of the session description 400 generated for modules 410, 411, 420 and 440 for transmission to end users is shown below in session description example 2.

```

20           ( # overall conference session
          type=(base)
          id=(410)
          info=(title="Multimedia98 Conference")
          source=(owner="Joe Bloggs" email=joe@nowhere.com)
          media=(video=(client=RealPlayerG2) whiteboard=(client=wb))
25           time(start="09:00 GMT 25/12/98" stop="13:00 GMT 25/12/98")
          options=(oc=411)
          modules=(b=420 b=430 b=440 oc=411)
          )

30           ( # conference track 1
          type=(base)
          id=(420 410)
          info=(title="MM98 Systems and Applications Track")
          source=(owner="Joe Bloggs" email=joe@nowhere.com)
35           media=(video=(client=RealPlayerG2) whiteboard=(client=wb))

```

```

time(start="09:00 GMT 25/12/98" stop="11:00 GMT 25/12/98")
options=(osq=424)
modules=(m=421 m=422 m=423 osq=424)

```

5

```

)
( # session QoS for track 1
  type=(option-sQoS)
  id=(424 420)
  mandatory=(421 422)
  optional=(423)
)

```

10

```

( # conference panel discussion
  type=(base)
  id=(440 410)
  info=(title="MM98 Panel Discussion")
  source=(name="Joe Bloggs" email=joe@nowhere.com)
  media=(video=(client=RealPlayerG2) whiteboard=(client=wb))
  time(start="11:00 GMT 25/12/98" stop="13:00 GMT 25/12/98")
  options=(osec=443)
  modules=(m=441 m=442 osec=443)
)

```

15

20

25

```

( # video for panel discussion
  type=(media)
  id=(441 440)
  info=(title="MM98 Panel Discussion Video")
  source=(owner="Joe Bloggs" email=joe@nowhere.com)
  media=(video=(type=live client=RealPlayerG2))
  connection=(226.0.0.106/1010 policy=444)
  time=(start="11:00 GMT 25/12/98" stop="13:00 GMT 25/12/98")
)

```

30

35

```

( # media QoS policy for panel discussion video
  type=(option-mQoS)
  id=(444 440)
  mechanism=(layer=(base=226.0.0.106/1010 number=3))
)

```

40

```

( # encryption policy for panel discussion
  type=(option-sec)
  id=(443 440)
  participant=(member=w3c)
  publickey=(location=http://www.w3.org/members_only/)
  info=(location=http://www.w3.org/)
)

```

45

```

( # charging policy for entire conference
  type=(option-chg)
  id=(411 410)
  mechanism=(type=AAA)
  price=(fee=1000GBP)
  info=(location=http://www.aaa.net/)
)

```

50

55

Session description example 2

Where there is surplus network bandwidth available, complete session descriptions can be announced to end users who may then elect to receive the announced session or parts thereof. However, the individual modules of the session description do not need to be announced together. If the network bandwidth available for announcements restricts the size of session descriptions, only the top level base module may be announced. In this situation, the link between modules may be, for example, a URI to a WWW or an intranet web site or server, an email address, an IP multicast address, an FTP address or details of a file or database stored on a local computer system from which an interested user can obtain the remaining modules.

The following session description example illustrates how the above session description for base module 420 would be changed if media module 421 was stored on a WWW server:

```
( # conference track 1
  type=(base)
  id=(420 410)
  info=(title="MM98 Systems and Applications Track")
  source=(owner="Joe Bloggs" email=joe@nowhere.com)
  media=(video=(client=RealPlayerG2) whiteboard=(client=wb))
  time(start="09:00 GMT 25/12/98" stop="11:00 GMT 25/12/98")
  options=(osq=424)
  modules=(m=421 location=http://www.announce.org/cgi-bin/module.cgi?id=421
           m=421 m=423 osq=424)
)
```

Session description example 3

Furthermore, top level modules of a session description may be announced well in advance of the actual transmission, at a time where the final details of content are unknown, in which case the remaining levels may be made available from pre-announced links at a later time.

Figure 5 is a schematic diagram of a system for managing media stream connections at a terminal of an end user system according to the present invention.

The session control system 500 is linked to an announcement receiving interface 510 and one or more multicast-capable multimedia applications 520. The session control system 500 and the announcement receiving interface 510 are connected to a network interface 530 via which announcements may be received and multicast transmissions may be initiated and/or received.

Announcements received at the network interface 530 are routed to the receiving interface 510. The receiving interface 510 decodes each announcement to obtain the session description and displays the user oriented information from the one or more base modules in a list to the user. The user is able to select a session description from the list announcing a session they wish to receive. The selected description is passed to the session control system 500 which determines which of the user's multimedia applications 520 are required for participation in the described session, starts the applications and initiates and provides the necessary media streams to the respective applications 520 via a communications manager 550.

The receiving interface 510 may be linked to other Internet communications applications 540 such as a WWW browser or an email client (not shown) which may be used to gather further information on the described session based on links provided in the session description. Also, where an incomplete set of base and/or media modules of a session description are received, the receiving interface 510 attempts to obtain the remaining modules using the Internet communications applications prior to passing it onto the session control system 500.

Figure 6 is a flow chart showing the steps taken by the session control system 500 upon receipt of a session description. The description is first parsed in step 600 to identify client applications for each media module. Once this is done a second parse is

carried out where applications are launched in step 610, that is to say for each media module start the application specified in the client field if that application has not already been started. The portion of the session description relating to the respective media type, i.e. the media module, the base module directly above the media module, all other modules attached to that base module and any other options modules that apply, is passed to the corresponding application in step 620. Since the media modules are marked with appropriate client applications, each application will be able to select those media streams that it wants to participate in. The application replies to the session control system with a connection request specifying its requirements in the form of a list of identifiers of media modules from which streams are to be initiated in step 630. The connection request is assembled by the session control system in step 640 and the system then parses the session description to identify other applications to launch in step 645. If a further media type is found, steps 610 to 640 are repeated, otherwise the session control system uses the assembled connection requests to form a list of media modules. This list is passed, together with a session QoS policy, to the communications manager, a system used in by the session control system, which determines according to the QoS policies and available system resources whether each connection request is viable.

The session QoS policy is constructed in two steps:- first, the multiple session QoS policies relevant for all the media modules to be initiated are combined into one session QoS policy: second, the resulting session QoS policy may be adapted to take account of (a) user default preferences (defined in a user profile), (b) a user's wish to determine the policy interactively, and (c) an application's default configuration (defined in the application profile(s)).

The communications manager responds to the session control system in step 650 with an indication of the viable media stream connection requests. If necessary,

the session control system may contact a charging system to initiate accounting for the session prior to requesting the communications manager to create the viable media stream connections in step 660.

5 Once a session starts, each received data stream relating to the session is passed to the associated multimedia application in step 670 until the scheduled stream time ends in step 680 or the multimedia application requests to the session control system that the connection is terminated in step 690, at which point the session control system disconnects the connection in step 700.

10 Figure 7 is a flow chart showing the QoS management step 650 of Figure 6 in greater detail.

15 Having received the assembled list of connection requests, the communications manager matches each item of this list to a media profile in step 705. A media profile defines requirements which must be met for the requested media stream to operate on the end user's computer including the minimum network bandwidth needed for satisfactory reception of the stream.

20 A terminal profile is determined in step 710. The terminal profile defines the resources which are available at the end user's computer for use by the requested media streams. This includes available network bandwidth, free memory and disk space and available hardware such as monitor size, processor speed and free audio and video capture devices. The media profile of each connection request is compared against the available system resources defined by the terminal profile in step 720. If the terminal profile matches or exceeds the media profile, the connection request is declared viable in step 730 and the terminal profile is decremented accordingly for the remaining connection requests in step 740. Each connection request is processed until there are
25 no remaining requests or until the media profile of a request exceeds the terminal profile. In this situation, the communications manager determines the optimum terminal

profile the user's computer would have if all non-essential applications were not running in step 750 and whether the computer is capable of fulfilling the media profile in step 760. If the computer is capable of fulfilling the media profile, the communications manager attempts to free system resources from currently allocated streams or connection requests which have lower priority or by asking the user to terminate other non-essential applications running on the computer in step 770. Alternatively, this could be done by reducing the number of layers received from a layered stream transmission. If sufficient resources cannot be found an exception is reported to the user and the connection request is marked as unviable. If the media stream that cannot be received is defined as mandatory in a QoS policy for a media session or subsession, all the connection requests for that media session or subsession are cancelled in step 790. If, however, the media stream is optional, the communications manager continues processing further connection requests in step 720. Once all pending connection requests have been processed, the communications manager reports those that are viable to the session control system.

The processing of a session description will now be described with reference to Figure 4 and session description example 4 which is the session description generated for Track 1 (modules 410 and 420-424 of Figure 4).

```

20      ( # overall conference session
        type=(base)
        id=(410)
        info=(title="Multimedia98 Conference")
        source=(owner="Joe Bloggs" email=joe@nowhere.com)
25      media=(video=(client=RealPlayerG2) whiteboard=(client=wb))
        time(start="09:00 GMT 25/12/98" stop="13:00 GMT 25/12/98")
        options=(oc=0010)
        modules=(b=420 b=430 b=440 oc=411)
30      )

      ( # conference track 1
        type=(base)
        id=(420 410)

```

```

5      info=(title="MM98 Systems and Applications Track")
      source=(owner="Joe Bloggs" email=joe@nowhere.com)
      media=(video=(client=RealPlayerG2) whiteboard=(client=wb))
      time(start="09:00 GMT 25/12/98" stop="11:00 GMT 25/12/98")
      options=(osq=424)
      modules=(m=421 m=422 m=423 osq=424)
    )

10     ( # video for track 1
      type=(media)
      id=(421 420)
      info=(title="MM98 Systems and Applications Track Video")
      source=(owner="Joe Bloggs" email=joe@nowhere.com)
      media=(video=(type=live client=RealPlayerG2))
15     connection=(226.0.0.100/1000)
      time=(start="09:00 GMT 25/12/98" stop="11:00 GMT 25/12/98")
    )

20     ( # audio for track 1
      type=(media)
      id=(422 420)
      info=(title="MM98 Systems and Applications Track Audio")
      source=(owner="Joe Bloggs" email=joe@nowhere.com)
      media=(audio=(type=live format=g711))
25     connection=(226.0.0.101/1001)
      time=(start="09:00 GMT 25/12/98" stop="11:00 GMT 25/12/98")
    )

30     ( # whiteboard for track 1
      type=(media)
      id=(423 420)
      info=(title="MM98 Systems and Applications Track Whiteboard")
      source=(owner="Joe Bloggs" email=joe@nowhere.com)
      media=(whiteboard=(client=wb))
35     connection=(226.0.0.102/1002)
      time=(start="09:00 GMT 25/12/98" stop="11:00 GMT 25/12/98")
    )

40     ( # session QoS for track 1
      type=(option-sQoS)
      id=(424 420)
      mandatory=(421 422)
      optional=(423)
45     )

```

Session description example 4

The session control system, having received the above session description, processes the tree structure of the session description starting at base module 410.

The first module encountered is base module 420. As this is not a media module but it does have sub-modules, the session control system continues down this branch to media module.

The media field of the media module 421 already defines the multimedia client application required as RealPlayerG2 (a multimedia application of Real Networks Inc) thus the session control system ignores it and continues to the next media module. The media field of the media module 422 does not have a multimedia client application defined, however a format for the audio data is specified. The session control system recognises that this particular audio format can be supported by RealPlayerG2 so it amends the media field to read client=RealPlayerG2. The next media module 423 has already defined a client application as wb so it ignores this module, and it also ignores the option module 424.

The session control system parses the tree structure again in order to launch client applications. The first media module 421 specifies that RealPlayerG2 should be launched, hence the session control system launches the application on the end user's system and keeps a record of this activity. The second media module 422 specifies an application that has already been launched and so the session control system ignores it and continues to the next media module. The media module 423 specifies that wb should be launched, so the session control system launches the application and keeps a record of this activity.

RealPlayerG2 is passed the media module 421, base module 420 and modules 422-424. The application processes the media modules given to determine which it can handle, and in this case it identifies 421 and 422. Having determined which streams it can handle, the application sends a connection request back to the session control system requesting connection to the media streams of modules 421 and 422. Similarly, wb is passed the media module 423, base module 420, modules 421-422, and the

module 424. The application processes the given modules as described previously, and requests connection to the media stream of modules 423.

The above connection requests are assembled by the session control system into a list, this list is then passed to the communications manager along with the session QoS policy module 424. The communications manager determines whether
5 each request is viable according to the steps of Figure 7.

Assuming there are sufficient resources for all the connection requests for mandatory media streams, the communications manager passes back a list of viable streams to the session control system which then processes the tree again to determine
10 the connection data held in the connection field of each media module so it can request that the communications manager initiate a connection to the appropriate media stream for each of the viable connection requests according to the connection data. The session control system then manages the session and its media stream connections as is described with reference to steps 670 to 700 of Figure 6.

15 Due to the heterogeneity of the Internet and differing capabilities and operating environments of end user computer systems, the session control system described has been implemented in Java (Java is a Trade Mark of Sun Microsystems Inc.). The announcement receiving interface, Session Directory, receives the announcements and passes those selected by the end user to the session control manager implemented as
20 an application programming interface running as a background process on the end user's computer.

Whilst the present invention has been described with reference to the Internet and multicast transmissions, it will be apparent to the reader that the described modular session description and the session control system are applicable to the announcement
25 and subsequent management of connections to media streams of a (multi)media session using other known transport mechanisms such as unicast.

Furthermore, although mechanisms for encryption, charging and other such services have not been explicitly described, it would be apparent to the reader that appropriate session descriptions and associated functions within the session control system for their processing could be readily implemented according to the mechanism required.

5

"SECRET" 6547E860

CLAIMS

1. A method of managing media stream connections for a media session, said method comprising the steps:-

- 5 receiving a session description of a media session;
- parsing the session description to determine appropriate media application programs for processing the or each media stream of the session description;
- selecting one or more media streams identified in the session description; and,
- connecting the or each selected media stream to one or more respective media application program or programs utilising a session control configured for managing media stream connections for the or each media application program.
- 10

2. A method according to claim 1, in which the selection of the or each media stream is carried out by the session control according to predetermined criteria.

15

3. A method according to claim 2, in which the predetermined criteria are specific to the preferences of at least one of the group consisting of an end-user, the terminal and the or each media application program.

20

4. A method according to any preceding claim, in which the media applications select one or more of the media streams identified in the session description which are required and pass respective connection requests to the session control.

25

5. A method according to any preceding claim, further comprising the step of passing at least a portion of the session description to the or each media application.

6. A method according to claim 5, in which the media applications generate or modify a quality of service policy for the connection requests for use by the session control.

5 7. A method according to claim 5 or 6, in which the media applications modify the session description for changing the subsequent management of connections by the session control system.

10 8. A method according to any of claims 4 to 7, in which the session control passes the connection requests to a terminal communications manager which determines whether the connection requests are viable and subsequently initiates the connections.

15 9. A method according to claim 8, in which the session control prioritises the connection requests from the media applications according to a quality of service policy to create a set of connection requests which are passed to the communications manager.

20 10. A method according to claim 8 or 9, in which the communications manager determines resources required for each connection request and whether the requests can be met given available resources.

11. A method according to claim 10, in which if the connection requests can be met the connections are initiated.

25 12. A method according to claim 10, in which if a connection request cannot be met and the connection request is for an optional media stream of the media session then

the communications manager proceeds by declaring the connection request unviable and moves to the next connection request.

13. A method according to claim 10, in which if a connection request cannot be met
5 and the connection request is for a mandatory media stream of the media session then the communications manager proceeds by attempting to free resources to meet the connection request.

10 14. A method according to claim 13, in which if the communications manager is unable to free sufficient resources to meet the connection request, the connection request is declared unviable and the communications manager refuses to join the media session.

15 15. A method according to any preceding claim, further comprising the step of obtaining a missing part of the session description by following a link or links in the session description before parsing the session description.

20 16. A system for managing media stream connections derived from a session description for a media session, the system comprising a session control for parsing the session description to determine appropriate media application programs for processing the or each media stream of the session description; the session control being configured to manage media stream connections for the media applications programs.

25 17. A system according to claim 16, in which the media application programs are arranged to select one or more appropriate media streams identified in the session description which are required and pass a number of connection requests to the session

control.

18. A system according to claim 16 or 17, in which the session control is arranged to pass at least a portion of the session description to the or each media application.

5

19. A system according to claim 18, in which the media applications are arranged to generate or modify a quality of service policy for the connection requests for use by the session control.

10

20. A system according to claim 18 or 19, in which the media applications are arranged to modify the session description for changing the subsequent management of connections by the session control.

15

21. A system according to any of claims 16 to 20, further comprising a communications manager for initiating the connections.

22. A system according to claim 21, in which the communications manager is arranged to determine whether the connection requests are viable and subsequently initiate the connections.

20

23. A system according to claim 21 or 22, in which the session control system is adapted to prioritise the connection requests for the one or more media streams from the media applications according to a quality of service policy to create a set of connection requests which are passed to the communications manager.

25

24. A system according to any of claims 21 to 23, in which the communications

manager is arranged to determine resources required for each connection request in sequence and whether the connection requests can be met given available resources.

25. A system according to claim 24, in which the communications manager is arranged to initiate the connections if the connection requests can be met.

26. A system according to claim 24, in which the communications manager is arranged to declare a connection request unviable and to move to the next connection request if the connection request cannot be met and it is for an optional media stream of the media session.

27. A system according to claim 24, in which the communications manager is arranged to attempt to free resources to meet a connection request if the connection request cannot be met and it is for a mandatory media stream of the media session.

28. A system according to claim 27, in which the communications manager is arranged to declare a connection request unviable and thereby refuse to join the media session if it is unable to free sufficient resources to meet the connection request.

29. A system according to any of claims 16 to 28, further comprising an announcement interface which is arranged to detect missing modules in a received session description and subsequently obtain them using location identifying links provided in the session description.

30. A computer readable storage medium containing executable instructions for performing the method of any of claims 1 to 15.

31. A terminal comprising at least one memory containing executable instructions for performing the method of any of claims 1 to 15.

702240 6540666

ABSTRACT

ANNOUNCED SESSION CONTROL

5 The invention provides a method and system for managing media stream
connections in a media session, for example a multimedia conference, that is to take
place over multicast capable links provided in networks configured for Internet Protocol
operation, that is to say, the communications network known as the Mbone (Internet
Protocol Multicast Backbone). The method comprises the steps of:- receiving a session
10 description of a media session by way of a session announcement over a network;
parsing the session description to determine appropriate media application programs for
processing the or each media stream of the session description (600); selecting one or
more media streams identified in the session description (630); and, connecting the or
each selected media stream to one or more respective media application program or
15 programs (660) utilising a session control (500) configured for managing media stream
connections for the or each media application program.

Figure 6

-

"0240" 6540660

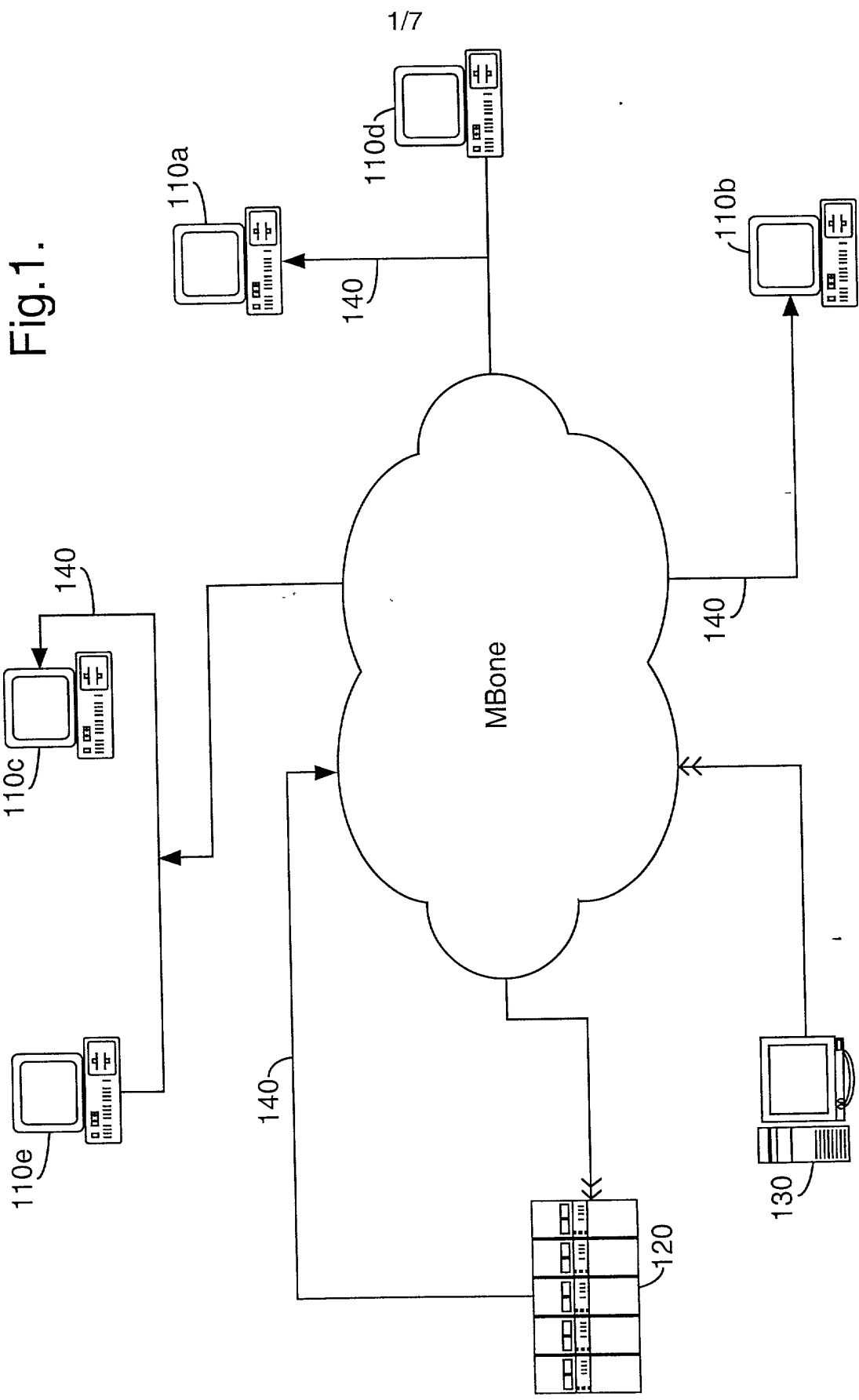

Fig. 1.

Fig.2.

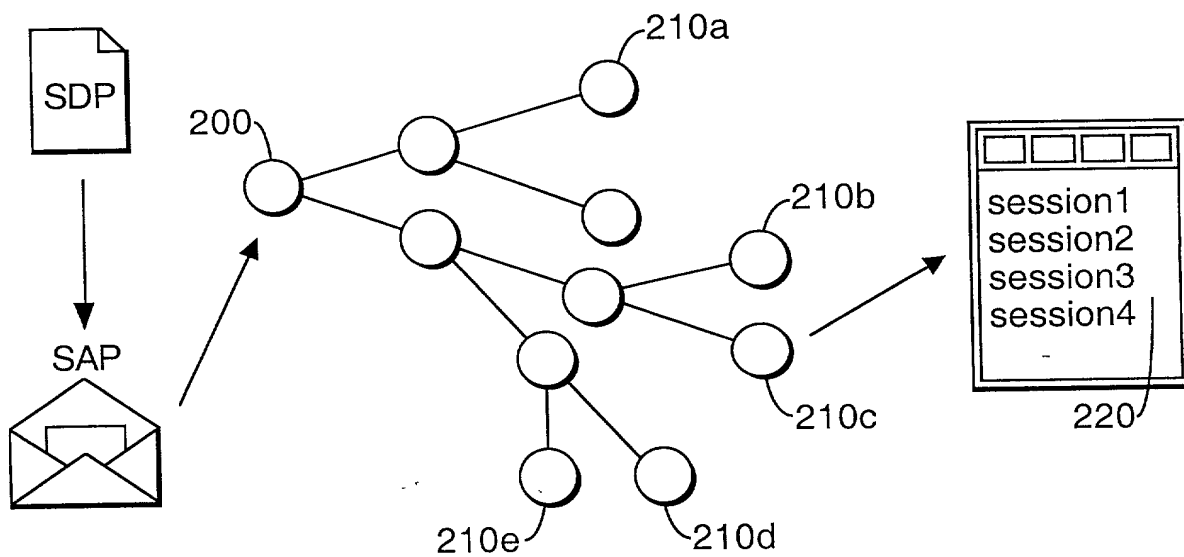

Fig.3.

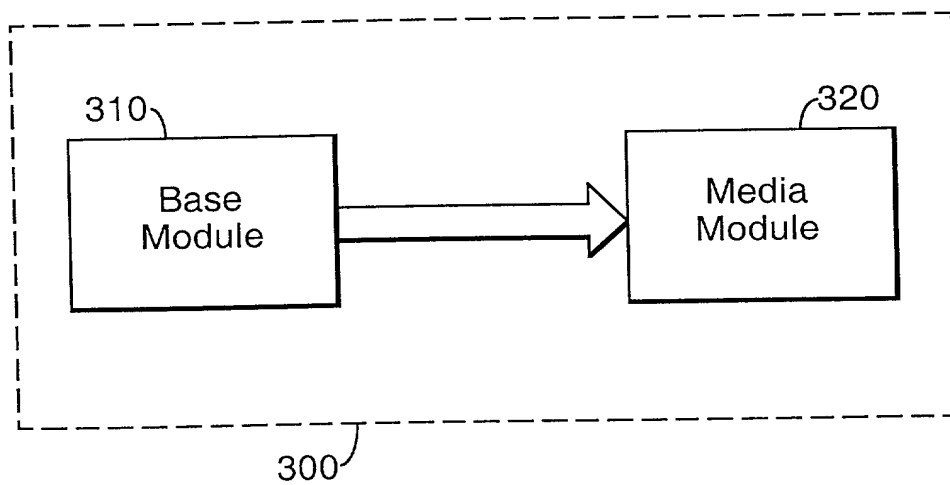

FIG. 2

Fig.4.

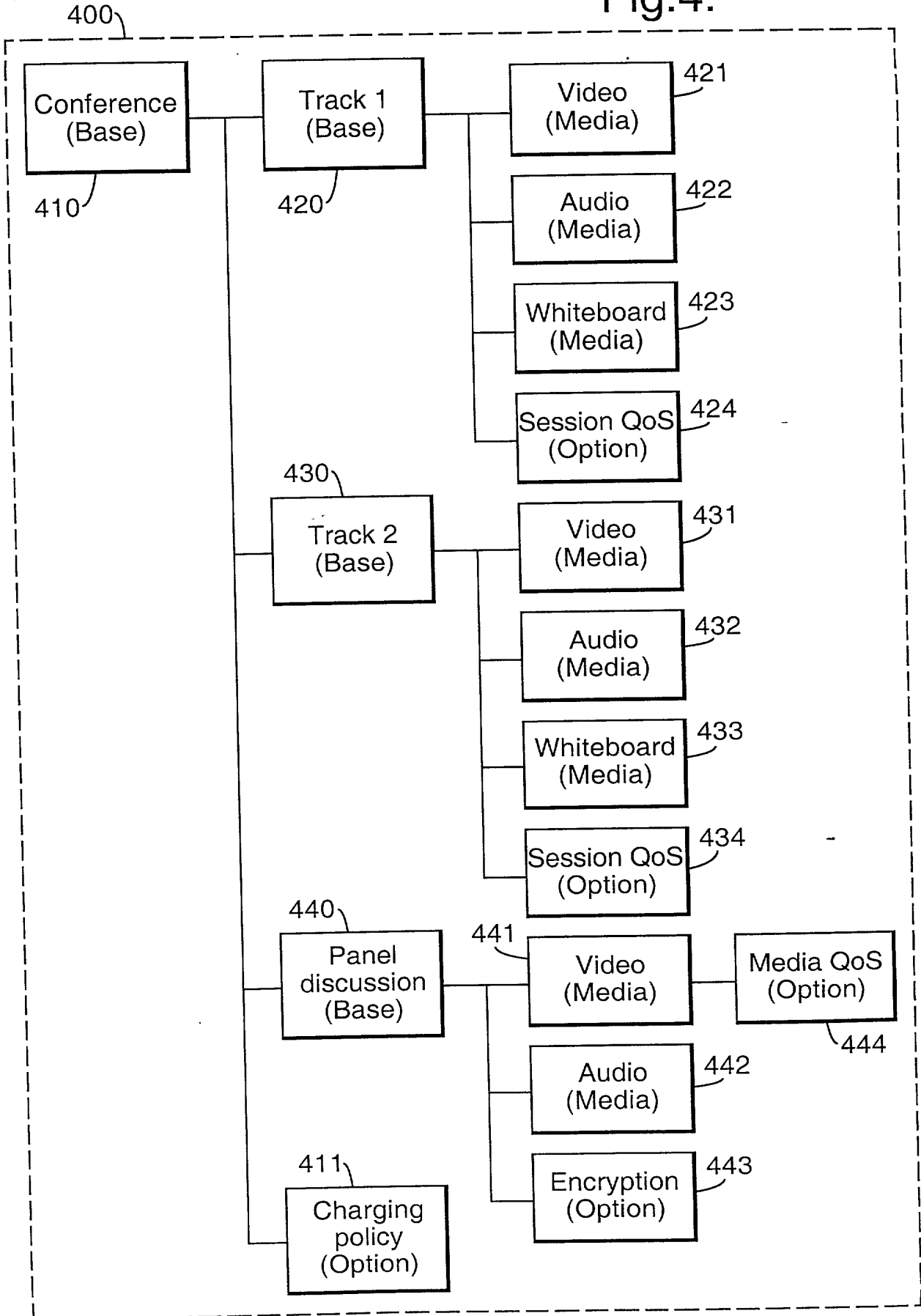
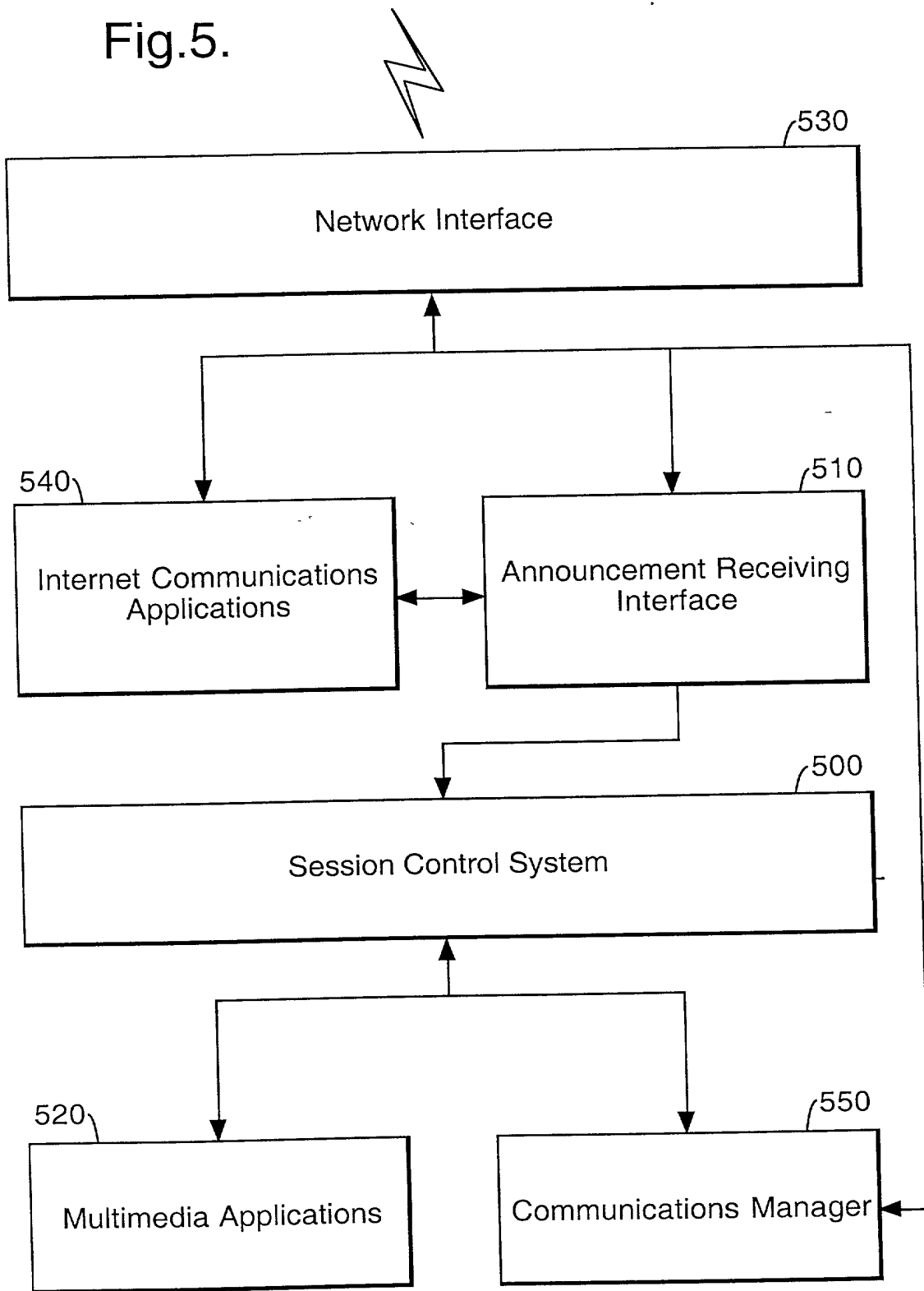

FIG. 4

Fig.5.



FOR PUBLICATION

Fig.6.

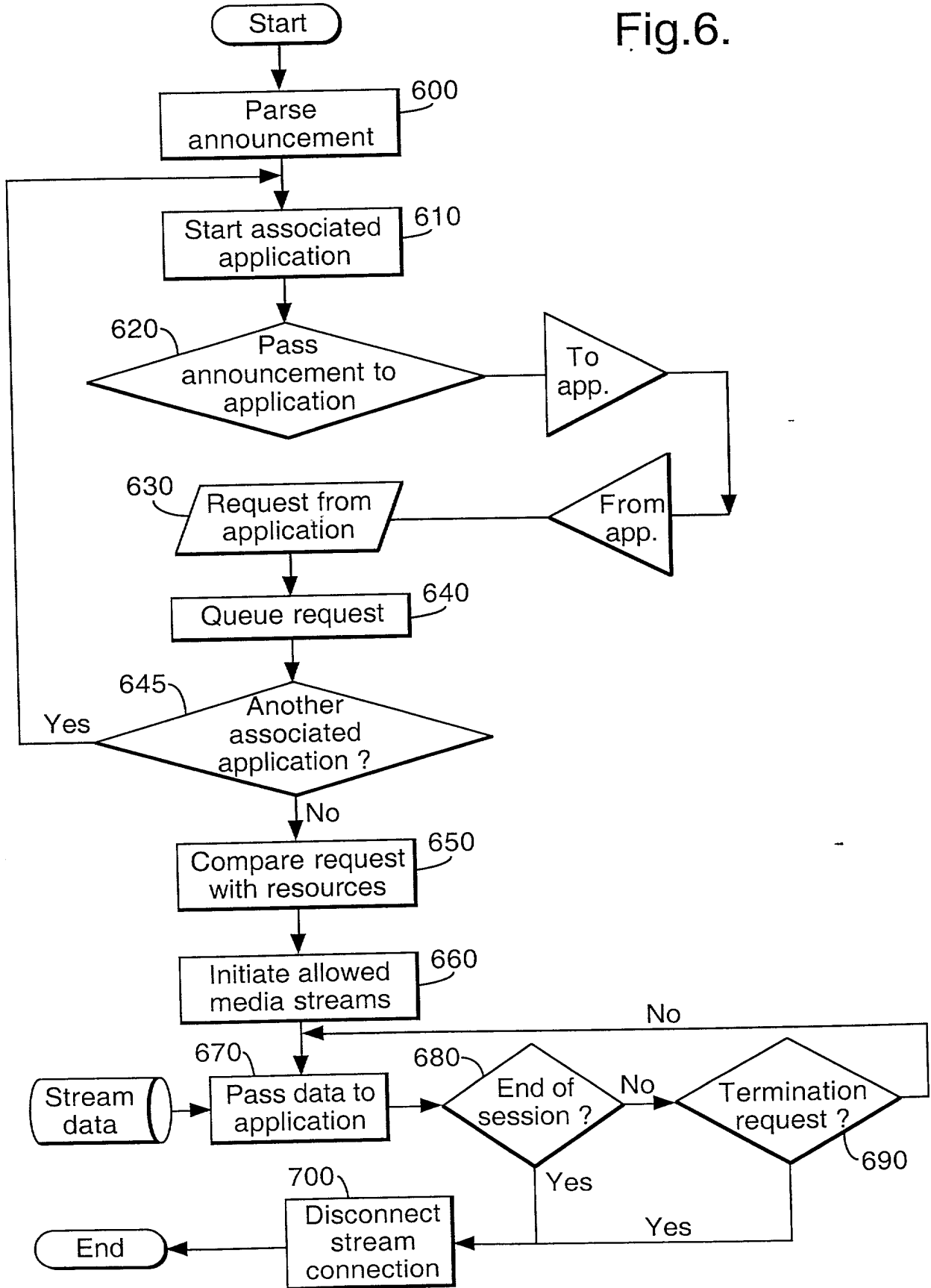

TO 240 65402660

6/7

Fig.7.

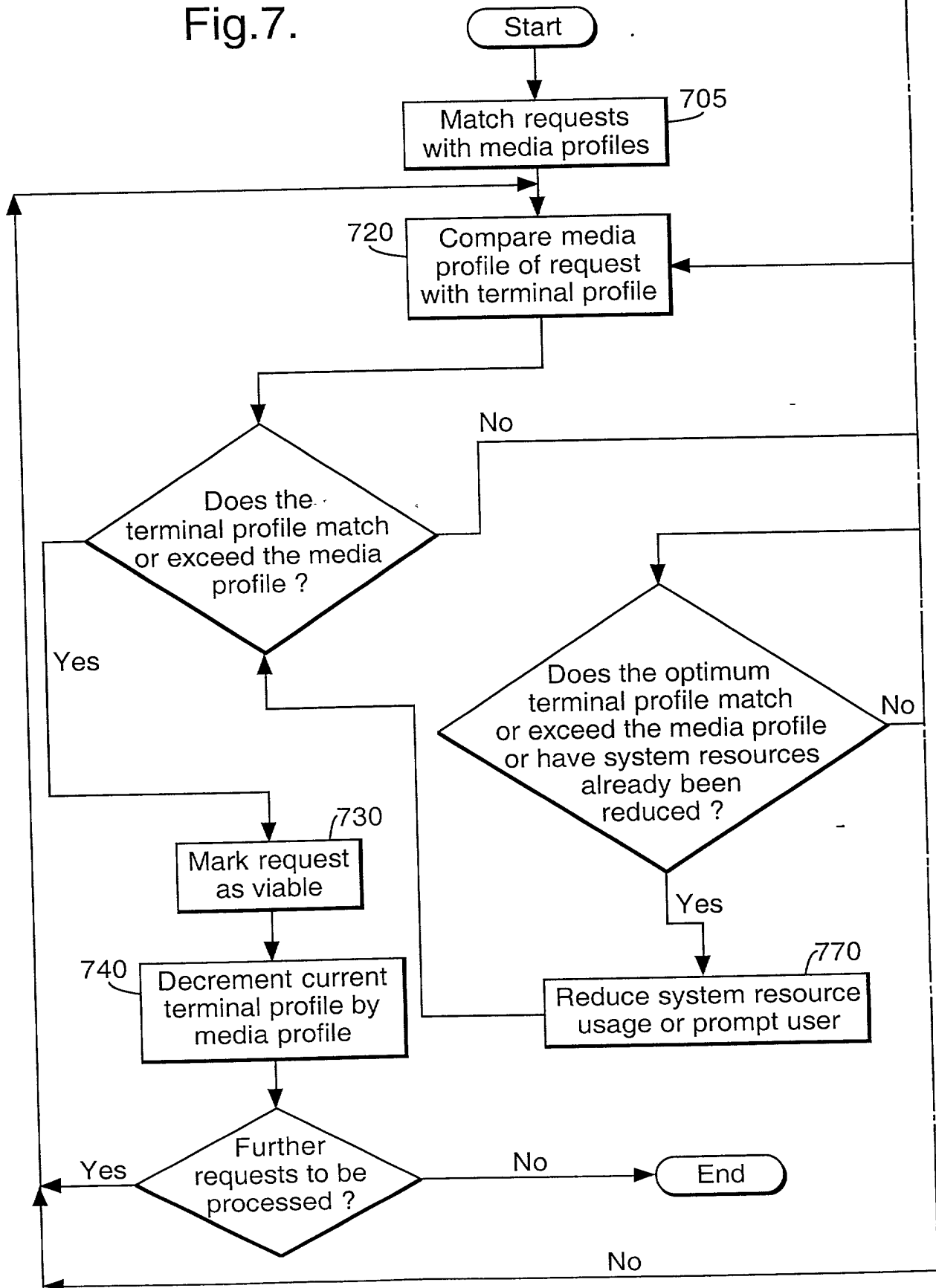
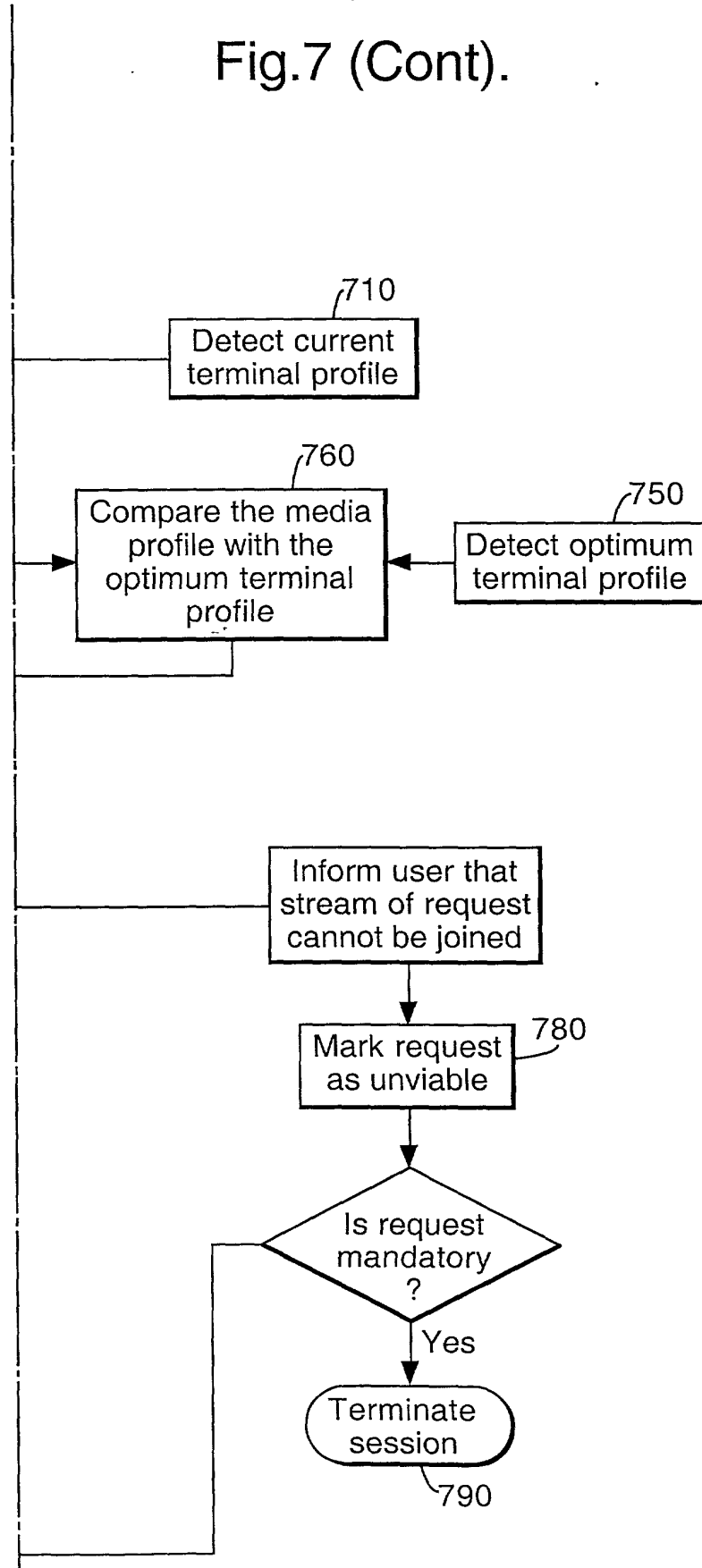

Fig.7 (Cont).

FIG. 7 (Cont.)



**RULE 63 (37 C.F.R. 1.63)
DECLARATION AND POWER OF ATTORNEY
FOR PATENT APPLICATION
IN THE UNITED STATES PATENT AND TRADEMARK OFFICE**

As a below named inventor, I hereby declare that my residence, post office address and citizenship are as stated below next to my name, and I believe I am the original, first and sole inventor (if only one name is listed below) or an original, first and joint inventor (if plural names are listed below) of the subject matter which is claimed and for which a patent is sought on the invention entitled:

ANNOUNCED SESSION CONTROL

the specification of which (check applicable box(es)):

- is attached hereto
- was filed on

as U.S. Application Serial No.

(Atty Dkt. No. _____)

was filed as PCT International application No. GB99/03870 on 19 November 1999
and (if applicable to U.S. or PCT application) was amended on _____

I hereby state that I have reviewed and understand the contents of the above identified specification, including the claims, as amended by any amendment referred to above. I acknowledge the duty to disclose information which is material to the patentability of this application in accordance with 37 C.F.R. 1.56. I hereby claim foreign priority benefits under 35 U.S.C. 119/365 of any foreign application(s) for patent or inventor's certificate listed below and have also identified below any foreign application for patent or inventor's certificate having a filing date before that of the application on which priority is claimed or, if no priority is claimed, before the filing date of this application:

Priority Foreign Application(s):

Application Number	Country	Day/Month/Year Filed
9826157.1	GB	27 November 1998

I hereby claim the benefit under 35 U.S.C. §119(e) of any United States provisional application(s) listed below.

Application Number	Date/Month/Year Filed

I hereby claim the benefit under 35 U.S.C. 120/365 of all prior United States and PCT international applications listed above or below and, insofar as the subject matter of each of the claims of this application is not disclosed in such prior applications in the manner provided by the first paragraph of 35 U.S.C. 112, I acknowledge the duty to disclose material information as defined in 37 C.F.R. 1.56 which occurred between the filing date of the prior applications and the national or PCT international filing date of this application:

Prior U.S./PCT Application(s):
Application Serial No.

Day/Month/Year Filed

Status: patented
pending, abandoned

PCT/GB99/03870	19 November 1999
----------------	------------------

I hereby declare that all statements made herein of my own knowledge are true and that all statements made on information and belief are believed to be true; and further that these statements were made with the knowledge that willful false statements and the like so made are punishable by fine or imprisonment, or both, under Section 1001 of Title 18 of the United States Code and that such willful false statements may jeopardize the validity of the application or any patent issued thereon. And on behalf of the owner(s) hereof, I hereby appoint **NIXON & VANDERHYE P.C., 1100 North Glebe Rd., 8th Floor, Arlington, VA 22201-4714, telephone number (703) 816-4000 (to whom all communications are to be directed)**, and the following attorneys thereof (of the same address) individually and collectively owner's/owners' attorneys to prosecute this application and to transact all business in the Patent and Trademark Office connected therewith and with the resulting patent: Arthur R. Crawford, 25327; Larry S. Nixon, 25640; Robert A. Vanderhye, 27076; James T. Hosmer, 36184; Robert W. Farris, 31352; Richard G. Besho, 22770; Mark E. Nusbaum, 32348; Michael J. Keenan, 32106; Bryan H. Davidson, 30251; Stanley C. Spooner, 27393; Leonard C. Mitchard, 29009; Duane M. Byers, 33363; Jeffrey H. Nelson, 30481; John R. Lastova, 33149; H. Warren Burnam, Jr. 29366; Thomas E. Byrne, 32205; Mary J. Wilson, 32955; J. Scott Davidson, 33489; Alan M. Kagen, 36178; Robert A. Molan, 29834; B. J. Sadoff, 36663; James D. Berquist, 34776; Updeep S. Gill, 37334; Michael J. Shea, 34725; Donald L. Jackson, 41090; Michelle N. Lester, 32331; Frank P. Presta, 19828; Joseph S. Presta, 35329. I also authorize Nixon & Vanderhye to delete any attorney names/numbers no longer with the firm and to act and rely solely on instructions directly communicated from the person, assignee, attorney, firm, or other organization sending instructions to Nixon & Vanderhye on behalf of the owner(s).

1. Inventor's Signature: Sarah K Bell Date: 17/11/00
 Inventor: SARAH BELL BRITISH
 (first) MI (last) (citizenship)
 Residence: (city) COTTENHAM (state/country) GREAT BRITAIN
 Post Office Address: 9 BRENDA GAUTREY WAY, COTTENHAM, CAMBRIDGE, GREAT BRITAIN
 (Zip Code) CB4 8XW

2. Inventor's Signature: Sarom Date: 12/10/2000
 Inventor: SAROM IMS BRITISH
 (first) MI (last) (citizenship)
 Residence: (city) IPSWICH (state/country) GREAT BRITAIN
 Post Office Address: 112 SPRING ROAD, IPSWICH, SUFFOLK, GREAT BRITAIN
 (Zip Code) IP4 2RR

FOR ADDITIONAL INVENTORS, check box and attach sheet with same information and signature and date for each.

-2-

S. Rudkin

Date: 12/01/2000

3.

Inventor's Signature:
Inventor:

STEVEN MI RUDKIN BRITISH
(first) (state/country) (last) (citizenship)

Residence: (city)

IPSWICH

GREAT BRITAIN

Post Office Address:
(Zip Code)

52 CORDER ROAD, IPSWICH, SUFFOLK, GREAT BRITAIN

IP4 2XD

GBN

FOR ADDITIONAL INVENTORS, check box [] and attach sheet with the same information and signature and date for each.